



bxxxxxy

[ˈbɒks ɒk]

Infinite furniture system

Developed by



VULCANUS

Inspiration

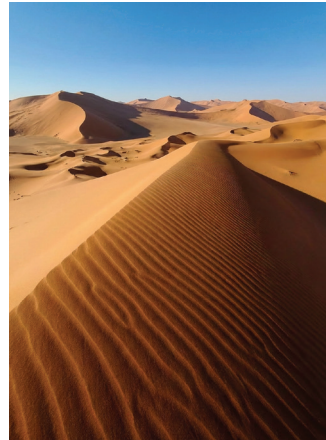

Design process

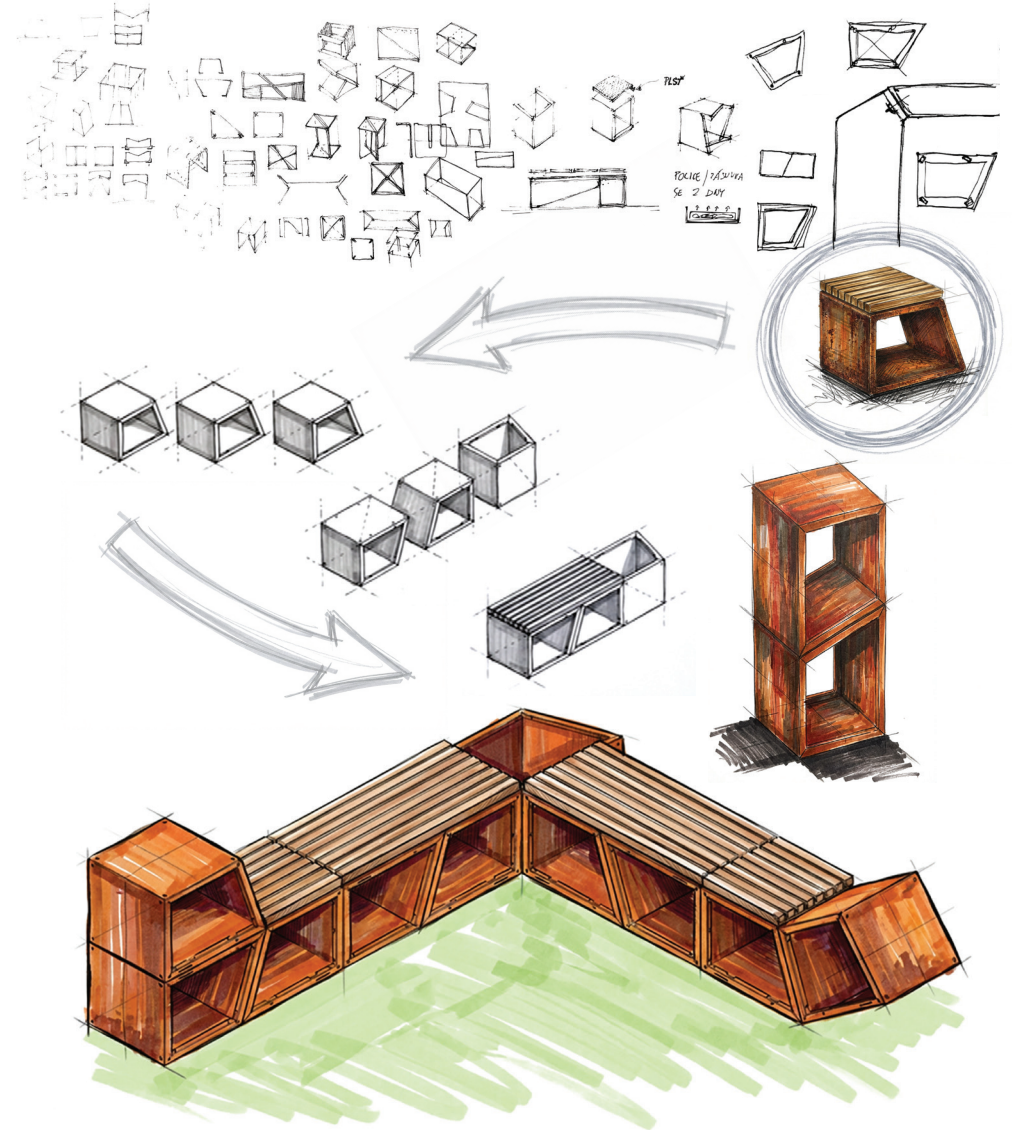

System logic

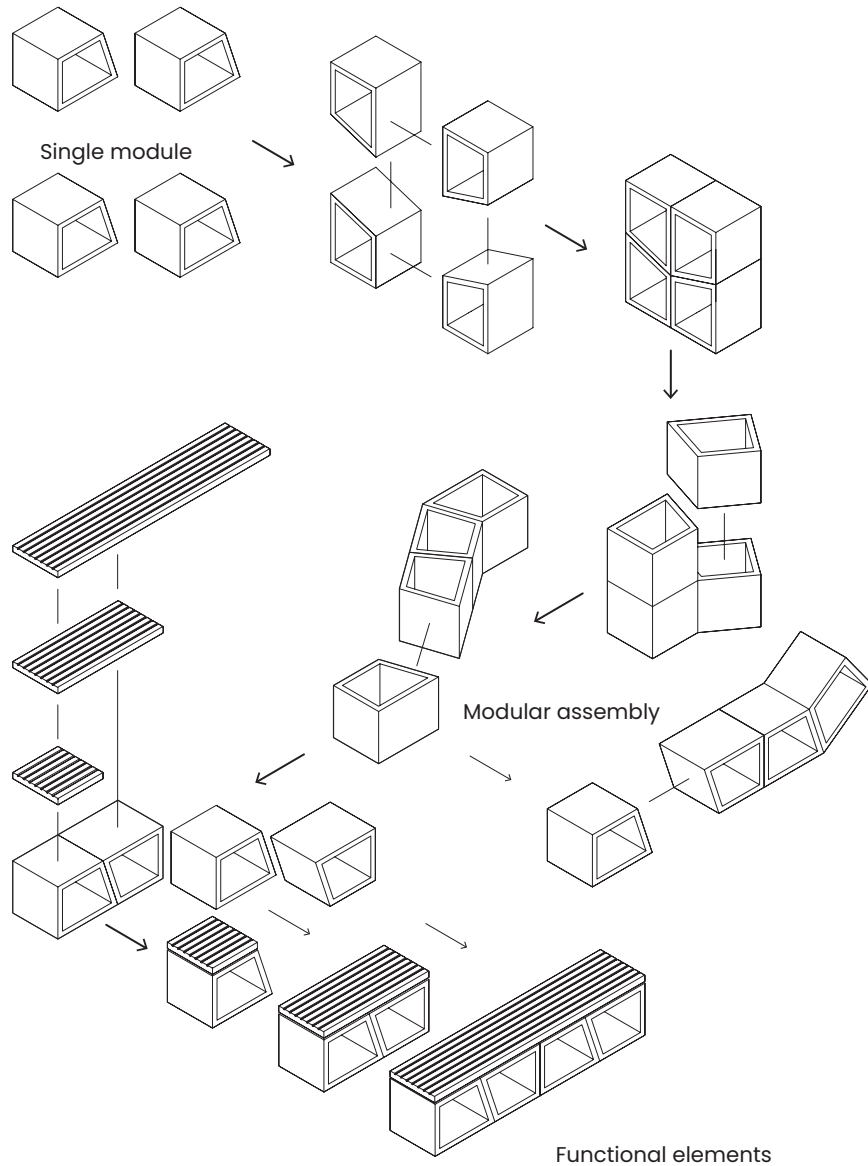

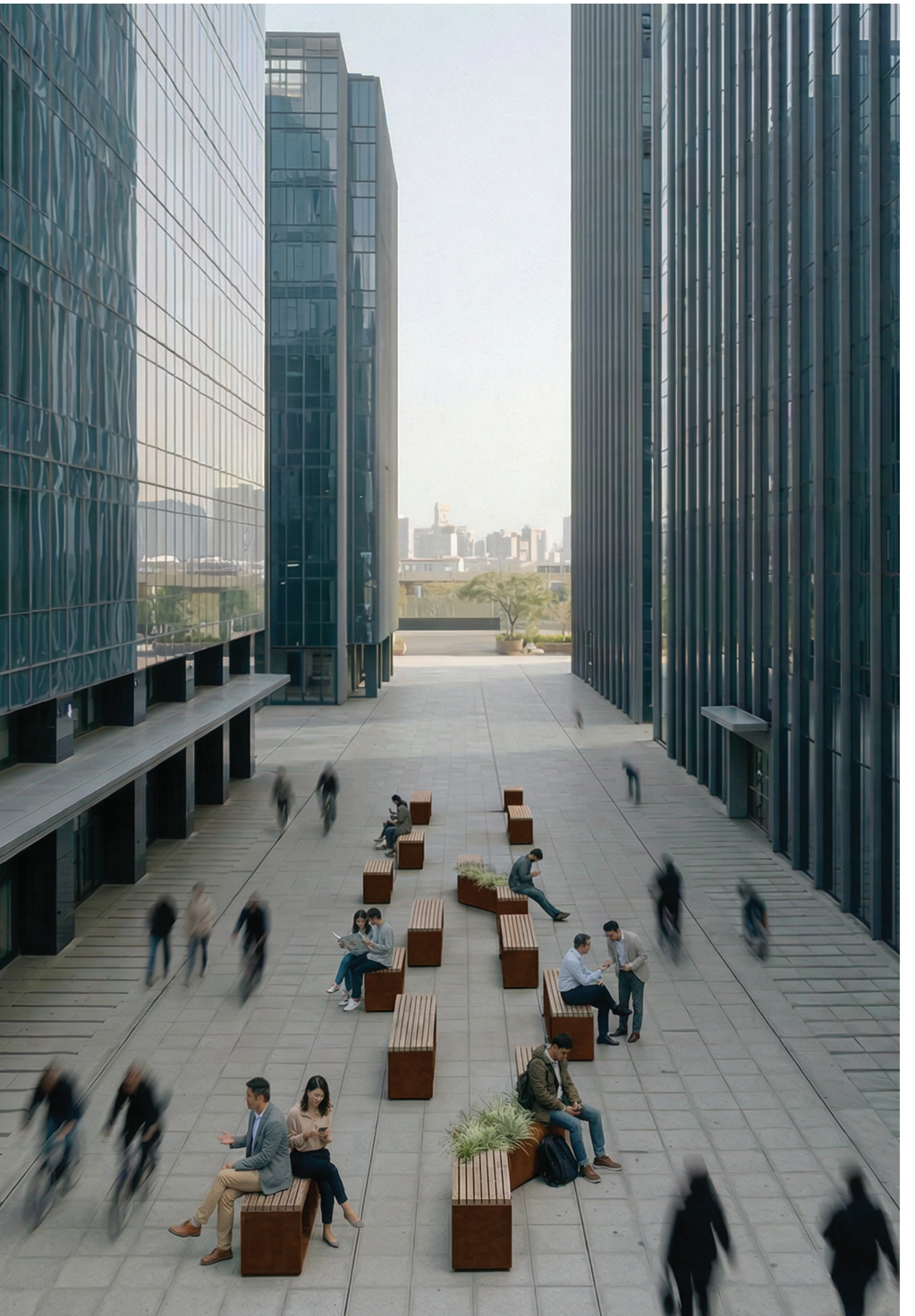

Products & dimensions

VULCANUS® boxxoq SoloSeat

W 528 mm / 20.8"
D 398 mm / 15.7"
H 446 mm / 17.6"
16 kg / 35.3 lbs



Catalogue no. 2300110

VULCANUS® boxxoq DuoSeat

W 927 mm / 36.5"
D 398 mm / 15.7"
H 446 mm / 17.6"
32.5 kg / 71.6 lbs



Catalogue no. 2300210

SSAB COR-TEN® steel
Thermowood pine
Stainless steel 1.4301

VULCANUS® boxxoq SoloPlanter

W 528 mm / 20.8"
D 398 mm / 15.7"
H 398 mm / 15.7"
14.5 kg / 32 lbs



Catalogue no. 2300310

VULCANUS® boxxoq DuoPlanter

W 760 mm / 29.9"
D 398 mm / 15.7"
H 398 mm / 15.7"
29 kg / 64 lbs



Catalogue no. 2300320

SSAB COR-TEN® steel
Recycled single-layer nonwoven fabric liner

VULCANUS® boxxoq QuadSeat

W 1853 mm / 73"
D 398 mm / 15.7"
H 446 mm / 17.6"
39.7 kg / 87.5 lbs



Catalogue no. 2300410

VULCANUS® boxxoq QuadSeat Plus

W 1853 mm / 73"
D 398 mm / 15.7"
H 446 mm / 17.6"
65.1 kg / 143.5 lbs



Catalogue no. 2300420

SSAB COR-TEN® steel
Thermowood pine
Stainless steel 1.4301

VULCANUS® boxxoq TriRest

W 1324 mm / 52.1"
D 398 mm / 15.7"
H 572 mm / 22.5"
48.6 kg / 107.1 lbs



Catalogue no. 2300330

VULCANUS® boxxoq QuadIsland 2x2

W 1056 mm / 41.6"
D 1056 mm / 41.6"
H 446 mm / 17.6"
64.5 kg / 142.2 lbs



Catalogue no. 2300430

SSAB COR-TEN® steel
Thermowood pine
Stainless steel 1.4301

Accessories

VULCANUS® boxxoq LogStack 2x2

W 796 mm / 31.3"
 D 398 mm / 15.7"
 H 972 mm / 38.3"
 51.6 kg / 113.7 lbs



SSAB COR-TEN® steel

Catalogue no. 2300510

VULCANUS® boxxoq Feet (set)



Catalogue no. 2300630

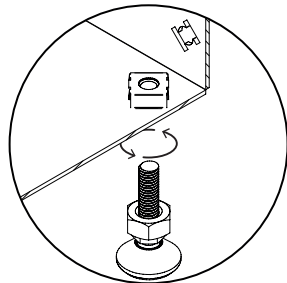

VULCANUS® boxxoq Insert



Catalogue no. 2300610

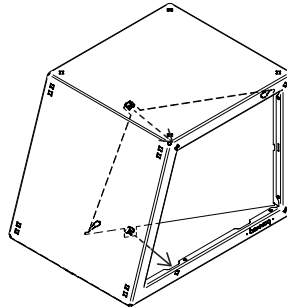

VULCANUS® boxxoq ShelfInsert

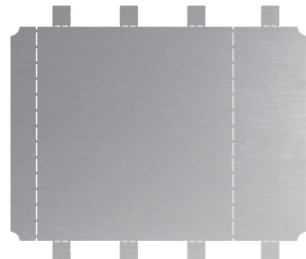

Catalogue no. 2300620

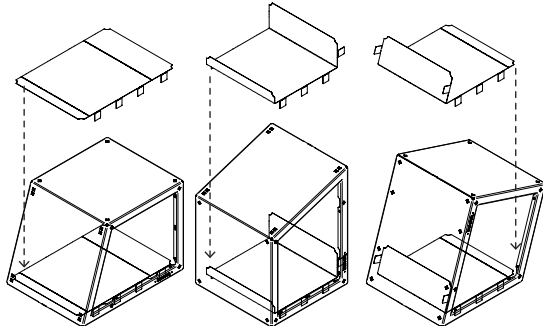

Materials



Public space & safety

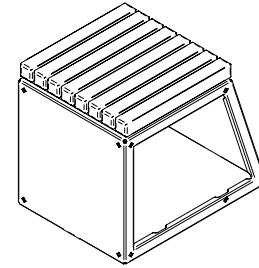

Sustainable & chemical-free materials

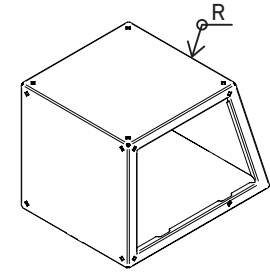

Safe geometry & rounded edges

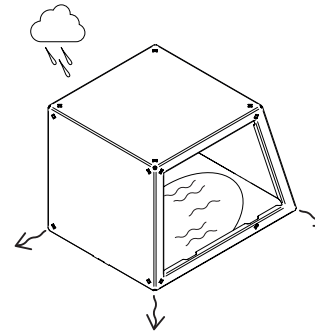

Weather resistance & drainage

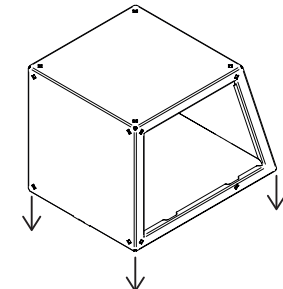

Stability & vandal protection

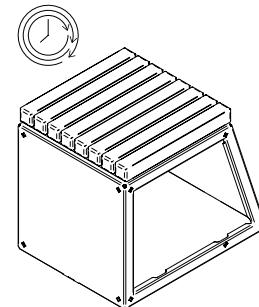

Long lifespan & low maintenance

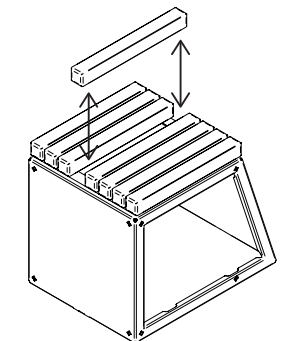

Modular repairability



Assembly



VULCANUS®
Manual

Easy & quick
Example: VULCANUS® boxxoq DuoSeat

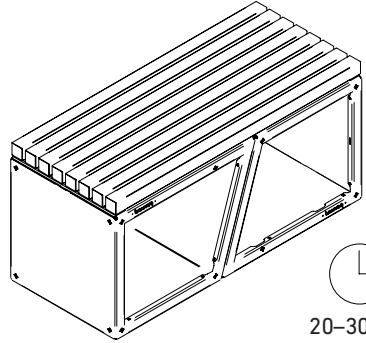

20-30 min

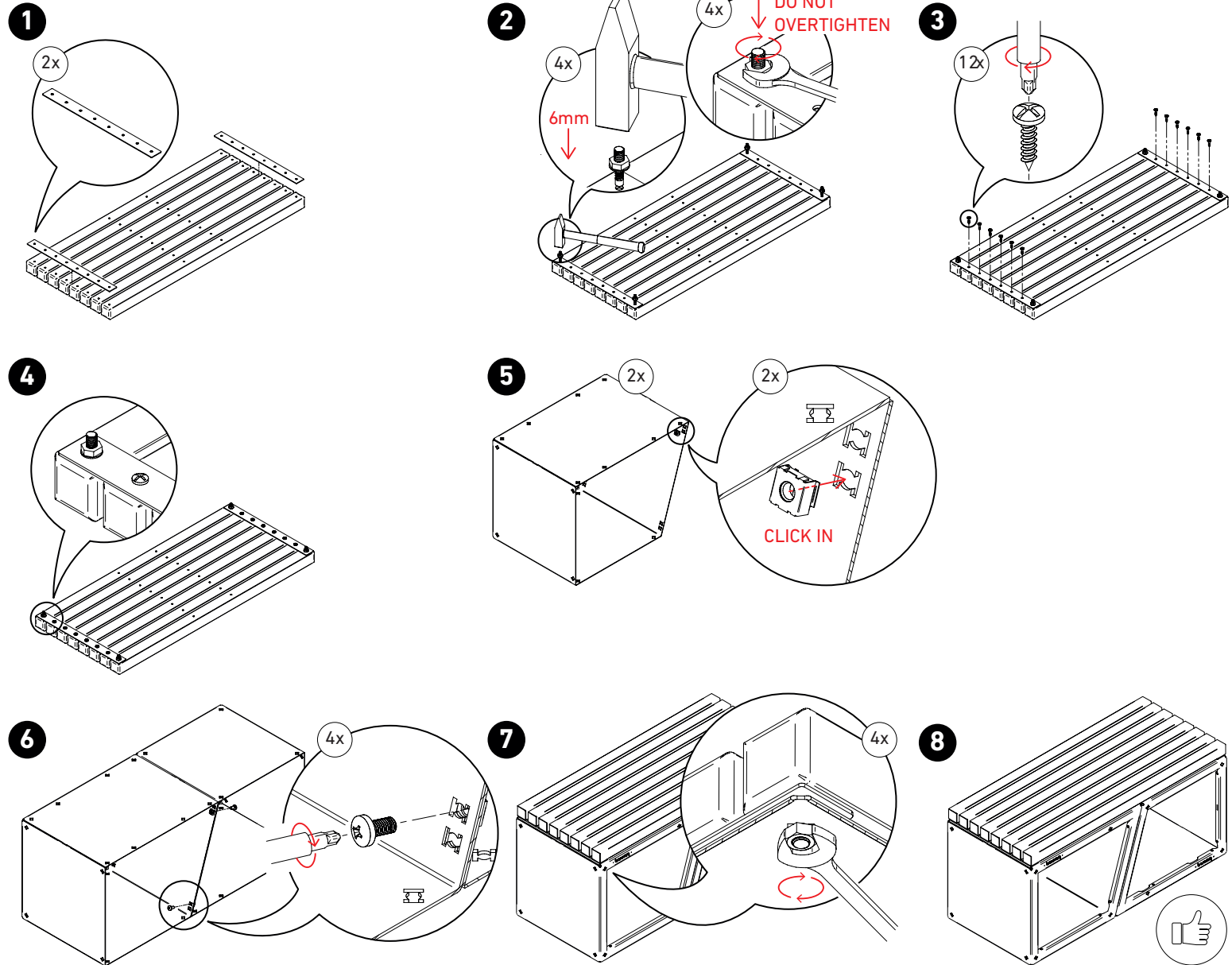
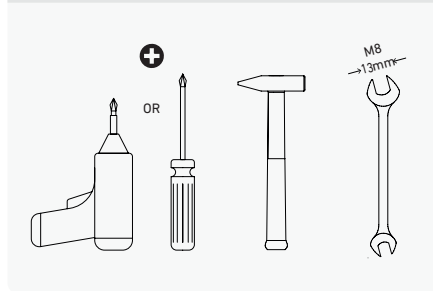
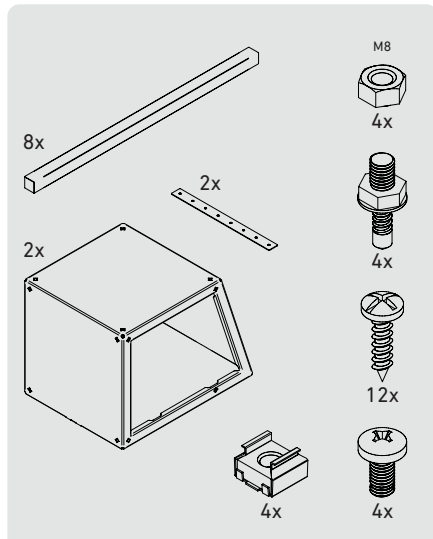



Resources & contact

Layout dimensions:

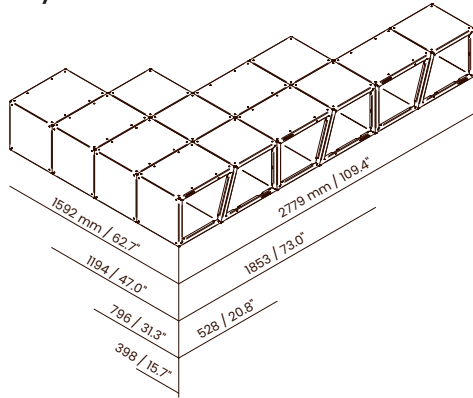

Retaining walls:

Walls exceeding two layers must be designed and verified by a qualified structural engineer.

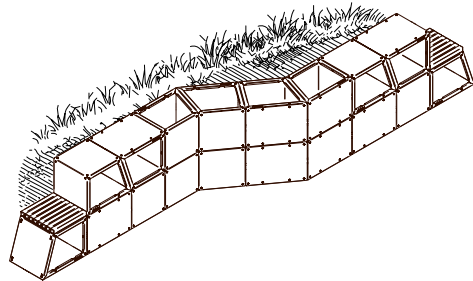

Anchoring:

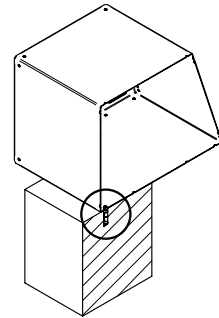

Concrete footing
with anchor

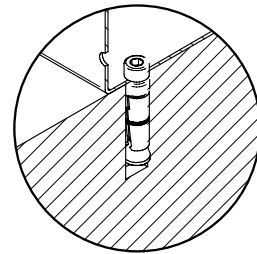

Drop-in anchor
—concrete slab
with granular
sub-base

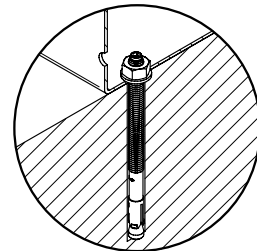

Expansion anchor
—concrete slab
base

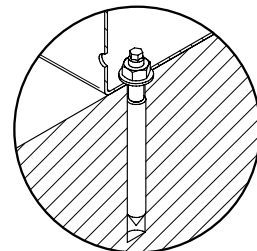

Chemical anchor
—universal
anchoring for most
surfaces

Resources:

Scan the QR to learn more or
download

- technical documents
- 3D CAD models (.3ds and .obj)
- marketing assets
- product animations



vulcanus-design.com/boxxoq

Layouts and projects support:

—tomas@vulcanus-design.cz

Transportation optimization:

24 pcs / EUR pallet
312 kg / 688 lbs

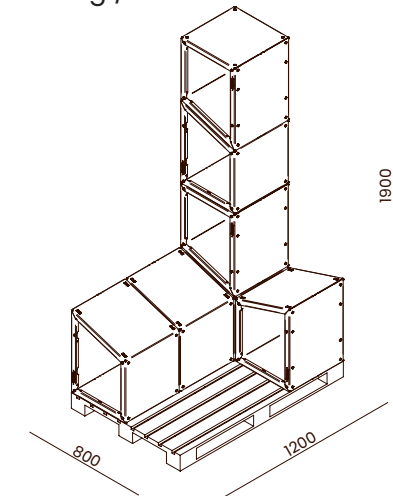

Contact:

VULCANUS design s.r.o.
Lazecká 344/4A
779 00 Olomouc
Czechia (EU)

ID: 05878926
VAT: CZ05878926

vulcanus-design.com
export@vulcanus-design.com

Inquiries and partnerships:

—export@vulcanus-design.com

boxxy



Made in EU

www.vulcanus-design.com

03 / 2026 rev1.0